

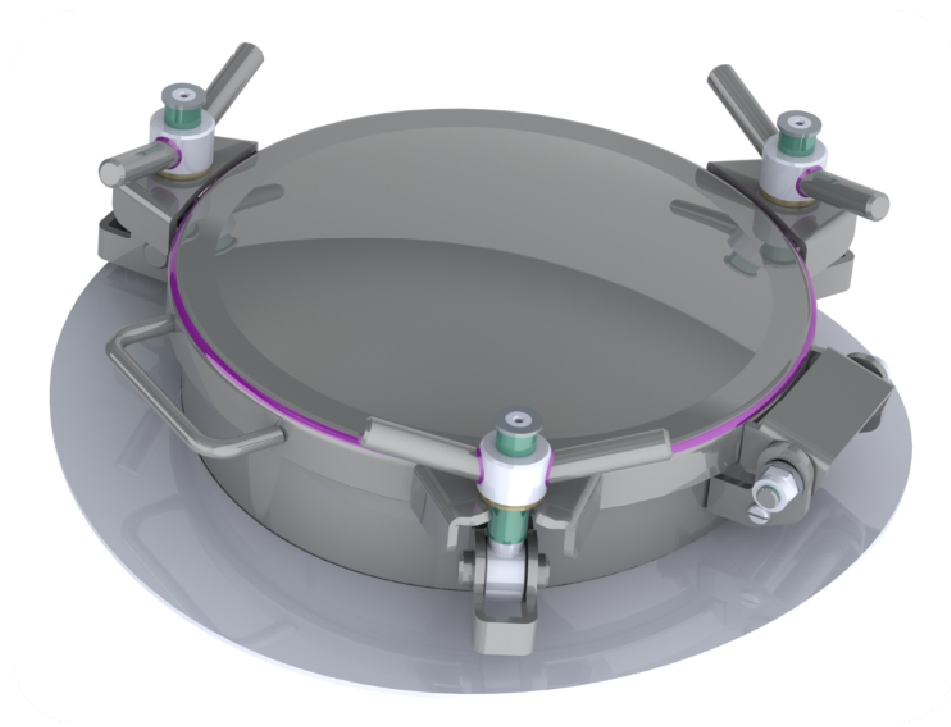

Use and maintenance handbook – Instructions for users



TYPE:

25R3-3-4; 25R3-4-4; (EN 1.4301 / EN 1.4307)

25R3-3-6; 25R3-4-6; (EN 1.4401 / EN 1.4404)



CONTENTS

1	OVERVIEW	3
1.1	DESCRIPTION OF THE EQUIPMENT	3
1.2	MANUFACTURER	5
1.3	IDENTIFICATION OF MAIN PARTS	6
1.4	PRODUCT ALLOWED AND LIMITATIONS	7
2	STORAGE	7
3	INSTRUCTIONS FOR INSTALLATION	7
4	OPERATOR'S WORKSTATION	9
5	PERMITTED USE OF THE INSPECTION OPENING	9
6	WARRANTY	9
7	INSPECTION AND MAINTENANCE CHECKS	10
8	PERIODIC CHECKS	10
9	ROUTINE MAINTENANCE	10
10	EXTRAORDINARY MAINTENANCE, MAINTENANCE SCHEDULE	11
11	DISMANTLING AND DEMOLITION: GENERAL INSTRUCTIONS	11



1 Overview

1.1 Description of the Equipment

Brief description of the function of the equipment

The number of tie rods on the inspection opening for tanks and containers used to transport dangerous goods pursuant to the 2015 edition of the ADR varies according to the working pressure inside the tank which also depends on the service temperature.

The inspection opening is only used to inspect tanks.

Depending on the type of goods transported, the inspection opening may be supplied with gaskets in the following materials: EPDM , NBR, NR FOOD GRADE, SILICONE and VITON.

The tank manufacturer must consider the tank construction material in relation to the inspection opening materials and choose the most suitable gasket according to the goods to be transported, also considering the temperature at which the dangerous goods are to be carried. Reference should be made to the technical data sheets of the inspection openings.

The pressure indicated on each item "P. max bar" refers to the maximum working pressure to which the inspection openings can be subjected. If the pressure value shown is exceeded, even accidentally, this could result in permanent damage to the inspection opening and loss of the contents, which could pose a hazard for people and objects.

The hydrostatic test pressure PT as defined by the PED Directive is based on the calculation pressure in the ADR technical reports, attached in the technical file. It is 1.43 times greater than the maximum allowable pressure (PS) as per point 7.4 of Annex I to the PED Directive.

DN	No. wing nuts	PS (bar)	PT (bar)	PED Ann.2 Tab.7
300	3	2.8	4	Art.3.3
300	4	4.2	6	Class I

VENETA ACCIAI is not responsible for the following activities resulting from:

- Incorrect welding of the inspection opening which may lead to deformations of the opening and could undermine the mechanical seal and strength of the components, at the maximum pressure.
- incorrect assembly due to installation on non-compliant equipment
- use with substances with which it is not compatible.



1.2 Manufacturer

NAME: VENETA ACCIAI S.r.l.

ADDRESS: Via delle Industrie, 9 30020 Fossalta di Piave (Venice) - Italy

CONTACT DETAILS: Tel. +39 0421 679996

Fax +39 0421 679470

E mail – General Manager: manager@venetaacciai.it

E mail – Sales Office: info@venetaacciai.it

E mail – Purchasing Department: supplier@venetaacciai.it

E mail – Technical Department: engineering@venetaacciai.it; production@venetaacciai.it

E mail – Accounting Department: administr@venetaacciai.it



1.3 Identification of main parts

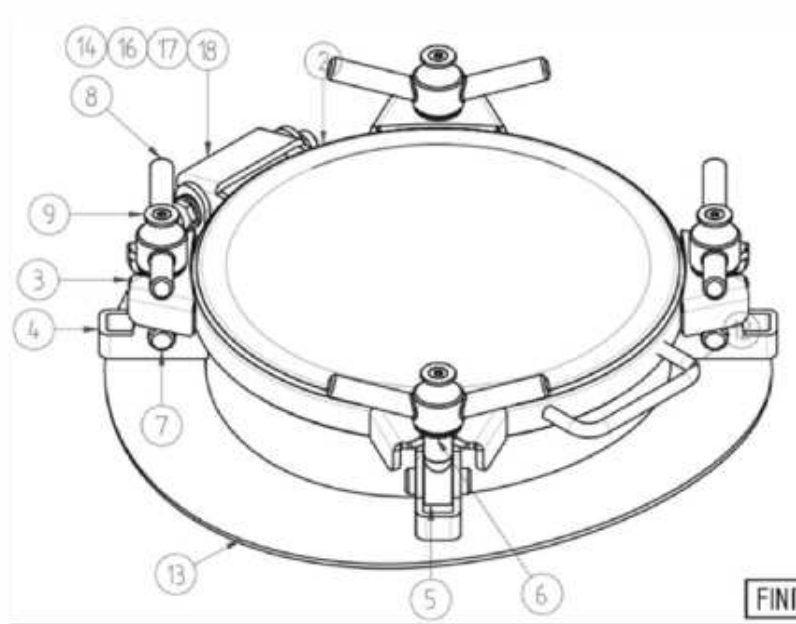

FIGURE	DESCRIPTION	FIGURE	DESCRIPTION
1	INSPECTION OPENING PLATING	12	HANDLE
2	COVER	13	REINFORCEMENT FLANGE
3	TIE ROD UPPER BRACKET	14	HINGE BRACKET
4	TIE ROD LOWER BRACKET	15	HINGE PIN
5	TIE ROD	16	HINGE WASHER
6	WASHER	17	HINGE NUT
7	TIE ROD PIN	18	HINGE ARM
8	HANDWHEEL	19	OPENING BLOCK ROD
9	WASHER	20	BUTTON HEAD SCREW



1.4 Product allowed and limitations

Technical specifications:

- Product compatible with materials available for inspection openings.
- Operating temperature $-20^{\circ}\text{C} + 200^{\circ}\text{C}$ depending on the number of closures present and maximum working pressure.

CCAGGIO

2 Storage

For correct storage, stand the inspection opening on the ground so that it rests on two wooden boards arranged one at each end.

If the inspection openings are not used for a long time (more than 6 months), check all parts subject to wear, especially gaskets.

3 Instructions for installation

During the installation of inspection openings by the tank manufacturer, due regard must be taken of the need, where applicable, to allow access with full rescue facilities including self-contained breathing apparatus through other openings.

The minimum dimensions of inspection openings installed in tanks with cladding must be preserved after the cladding has been applied.

The inspection opening plating and the tank plating must be welded by means of double fillet welds on both sides. The welds must be of a suitable thickness depending on the thicknesses used for the tank plating.

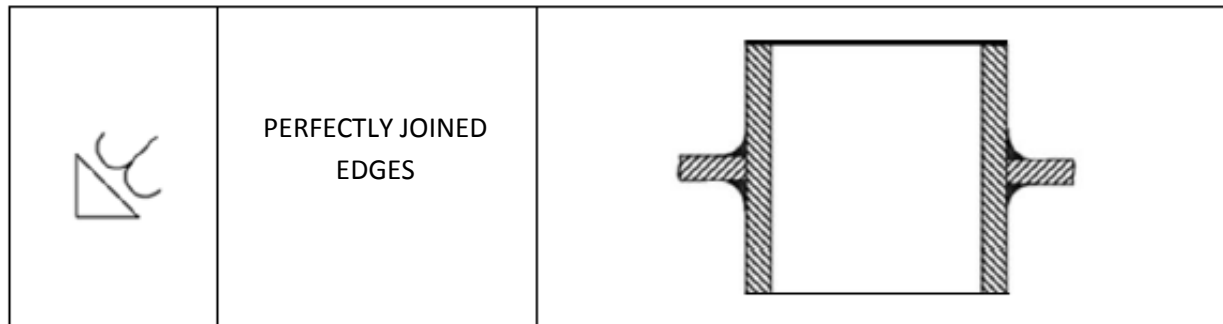

Assembly and welds must be performed in accordance with the relevant standards by qualified welders.

To guarantee the correct installation of the inspection opening, welds must be inspected by performing liquid penetrant non-destructive tests to evaluate the integrity and tightness of the weld and of the actual product.

It is possible, under reasonably foreseeable conditions, that the user exceeds the allowable limits, the pressure equipment is not fitted with adequate safety devices, unless it is to be protected by other protective devices incorporated in the plant.

The final fitter must therefore consider using the following additional devices, if required, to overcome the problem:

- Pressure limiting devices;
- Temperature controllers.



4 Operator's workstation

Inspection openings do not require the presence of an operator except to open and close the cover during work on the inspection opening or when it is being cleaned or inspected.

When mounted on tanks on road vehicles, inspection openings must be accessed via gangways that meet the applicable standards.

Operators may be exposed to risks associated with working at heights and to the risk of injury to the limbs due to crushing. In addition to the procedures envisaged by the manufacturer of the tank/cistern or by the operator's employer, who must have drawn up the related risk assessment document for the specific job, the correct use of at least the following PPE (Personal Protective Equipment) is recommended: gloves to prevent crushing injuries and with an anti-slip grip, shoes with non-slip soles, work overalls with closed sleeves and trousers to prevent clothing from getting caught, equipment to prevent falling and safety hat.

5 Permitted use of the inspection opening

The tank or each of its compartments must be fitted with a means of access to allow inspection of the inside. The inspection opening may be used to load products compatible with the material used and/or to clean the tank. This use is defined by the tank manufacturer.

Users and operators must comply with all applicable regional and company health and safety regulations.

Any forms of use other than that indicated above are regarded as improper use and may result in damage to the part and injury of operators, for which VENETA ACCIAI S.r.l. declines all liability.

6 Warranty

Any use other than that expressly permitted will render the warranty null and void.

The warranty does not cover repairs carried out using spares not provided by VENETA ACCIAI S.r.l.



7 Inspection and maintenance checks

Inspections of the inside of the inspection opening carried out from within the tank/cistern must be performed by qualified technicians. Such inspections must be performed by specialised technicians since they involve a very high risk of danger and even of fatal injury owing to the type of product stored, which may be toxic, explosive or harmful.

Only perform internal inspections after the tank/cistern has been degassed or when adequate ventilation has been established in the confined space to maintain a safe atmosphere. Follow all the procedures for entering a confined space or an area of suspected pollution.

8 Periodic checks

Visual inspections:

- Check the gaskets of the inspection opening for any deformations or cracks.
- Check the condition of the closing tie rods and cover coupling pins;
- Check for any leakages, dripping or dampness;

NB: any defects should be reported immediately to the technical assistance service.

NB: before carrying out inspections or maintenance work, make sure that the tank in which the inspection opening is installed has been degassed.

9 Routine maintenance

NB! The tasks listed below may be carried out by specialised maintenance technicians or general labourers who have been adequately trained and instructed.

Keep the inspection opening clean and remove any deposits of dust or foreign matter, especially between the gasket and the frame of the inspection opening; taking this precaution facilitates periodic maintenance inspections, which are necessary to guarantee lasting operation of the inspection opening and of the brackets and tie rods.



10 Extraordinary maintenance, maintenance schedule

NB! The following tasks must be performed by specialised maintenance technicians.

Always use original spare parts.

Check the data plate or marking to make sure they are clearly legible and contain essential data about the inspection opening; when installing the inspection opening on a tank, we recommend copying this information into the tank's maintenance manual.

11 Dismantling and demolition: general instructions

This chapter describes the procedures for dismantling and disposing of the inspection opening.

The inspection opening must be disposed of in accordance with the regulations in force in the country of use.

If the inspection hole is to be scrapped, its parts must be disposed of separately according to their different types (metal, plastic, rubber, etc.).

If possible, use specialised companies authorised for the purpose and in any case in compliance with the law.

We recommend that you consult your local waste disposal plant.

The inspection opening must be disposed of properly at the end of its life.